



## Add-on radio module WFZ16.O / WFZ166.O

Add-on modules to retrofit compact heat meters, series G 20 - G 58, arithmetic units, series R 20 - R 28 and split heat meters for use in the systems Q walk-by and Q AMR. The add-on module accepts the data from heat meters and transmits them to a readout system. The add-on module is equipped with an optical interface for parameter setting.

## Application

Add-on radio modules of the type WFZ16.. are part of the Q AMR system,  
Add-on radio modules of the type WFZ166.. are part of the Q walk-by system.  
Both options are used if heat meter, series G20/21, G54/55/58 and arithmetic units, series R20/21/28 are present, whose data must be measured within one of these systems.

## Functions

- ~ Acquisition of the heat measurement data from the heat meter and/or arithmetic unit
- ~ Acquisition of the cooling energy measurement data for combined heat and cold metering
- ~ Storage of consumption data and Due date values
- ~ Readout via radio and transmission of the consumption values to a readout unit without direct access to the device
- ~ The add-on radio module does not have its own display
- ~ The transmission period is always given as CET for the entire year

## Transmitted data

- ~ Current consumption value
- ~ Due date value
- ~ Due date
- ~ 13 monthly values
- ~ Error code
- ~ Error date

## Parameter setting possibilities when using the service software

WFZ16..  
WFZ166..

---

WFZ166..

---

- ~ Customer location as freely assignable field
- ~ Time delay (offset) in days to the readout day
- ~ Weekdays without telegram transmission
- ~ Transmission time within one day  
(e.g. 8 am – 6 pm CET)
- ~ Changing parameter setting for use in Q AMR system  
(not reversible)

The measuring devices transmit status information several times a day for the entire year independent of the readout time set.

## Type summary

Type designation		System
WFZ16.OF	Add-on radio module with remote antenna	Q AMR
WFZ16.OK	Add-on radio module with integrated radio antenna	Q AMR
WFZ166.OF	Add-on radio module with remote antenna	Q walk-by
WFZ166.OK	Add-on radio module with integrated radio antenna	Q walk-by

## Ordering

The complete order number must be given for the order.

As a default, the add-on radio module WFZ166.O is set to the following:

- ~ Annual readout
- ~ Time delay to readout day 0 days
- ~ Daily transmission time from 8 am to 6pm
- ~ No telegram transmission on Sundays

## Device combination

One add-on radio module is required per heat meter.

## Technical data

### General device data

Rated voltage	DC 3 V
Service life	11 years + 6 months reserve
Battery type	Varta CR 2/3 AA
Data transmission according to	EN 13757/4
Frequency band	868.0 MHz to 868.6 MHz
Transmission power	Typically 5 dBm
Permissible ambient temperature	
during transport	-20 °C to max. +70 °C
during storage	+5 °C to +55 °C
during operation	+5 °C to +65 °C

### Standards and norms

CE conformity	Directive 1995/5/EC (R&TTE Directive) Legislation concerning radio systems and telecommunications equipment (FTEG)
Protection rating	IP 54
Protection class	III
Electromagnetic compatibility	
Interference resistance	EN 301 489-1/-3
Emitted interference	EN 300 220-2
Security of IT equipment	EN 60950-1

Dimensional drawing

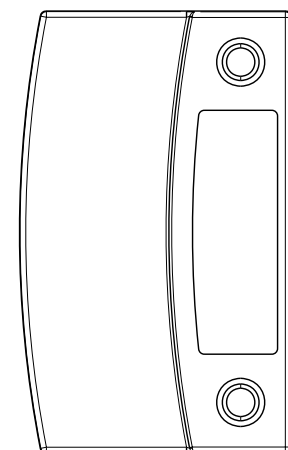
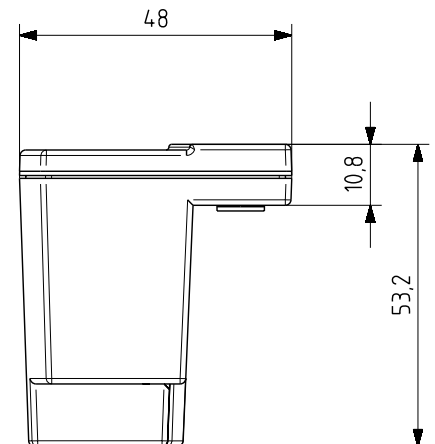
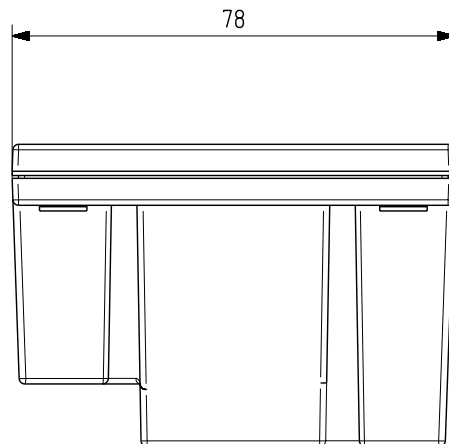

**QUNDIS GmbH**

Sondershäuser Landstraße 27  
99974 Mühlhausen / Germany  
Tel.: +49 (0) 3601 46 83-0  
Fax: +49 (0) 3601 46 83-175  
e-mail: info@qundis.com

Bahnhofstraße 10  
78112 St. Georgen / Germany  
Tel.: +49 (0) 7724 93 89-0  
Fax: +49 (0) 7724 93 89-310  
e-mail: info@qundis.com

The information in this data sheet only contains general descriptions or product characteristics, which may not always apply in particular application cases and/or may be subject to change through further development of the product.  
Required product characteristics are then binding if they are expressly agreed when the contract is drawn up.  
©2010 QUNDIS GmbH. Subject to change