



## Electronic Heat Meters in Measuring Cell Design

**WMM...**

---

**Electronic mains-independent meters designed to acquire heat consumption in autonomous heating and DHW plants.**

**Storage and display of cumulated values on a selectable set day.**

**Measuring cell as a compact all-in-one or split version.**

**Nominal flow with multi-jet version 1.5 m<sup>3</sup>/h and 2.5 m<sup>3</sup>/h.**

**The electronic heat meter measuring cell is a component of the Q AMR and the Q M-Bus Systems.**

---

### Use

The electronic measuring cell heat meters are used to acquire heat consumption. Main fields of application are systems with central heat generation, where heating energy is delivered to several individual consumers.

The meters are suitable for:

- Apartments
- Office and administrative buildings

Typical users are:

- Private building owners

- Residential cooperatives
- Building service firms
- Housing estate agents

## Functions

- Acquisition of heat consumption based on the flow rate and the temperature differential
- Cumulation of consumption values
- Storage of cumulated consumption values on a set day
- Display of consumption values
- Display of key operating data
- Self-monitoring with error display
- Data transmission via M-bus, radio and pulse output (open collector)

## Basic design of measuring cell

The measuring cell meter consists of measuring cell and single-pipe connecting piece (EAT) and is designed such that the measuring cell can be installed and replaced as a complete unit.

The measuring cell has a body made of brass which accommodates the measuring chamber with the impeller. The water hits the impeller as a multi-jet.

The single-pipe connecting piece is made of brass and has 2 connections for installation and a 2" internal thread, into which the measuring cell is screwed. It is fitted into the piping system by screwing or soldering the single-pipe connecting piece.

### Type summary - measuring cell type heat meters $Q_p = 1.5 \text{ m}^3/\text{h}$

Nominal flow $q_p$	Cable length Temperature sensor	Flow sensor	Return sensor	Communication	Type reference **
1.5 m <sup>3</sup> /h	1.5 m	Indirect	Direct/integrated	For M-bus *	<b>WMM31.D001</b>
1.5 m <sup>3</sup> /h	2.5 m	Indirect	Direct/integrated	For M-bus *	<b>WMM31.D002</b>
1.5 m <sup>3</sup> /h	1.5 m	Indirect	Direct/integrated	Pulse output	<b>WMM34.D001</b>
1.5 m <sup>3</sup> /h	2.5 m	Indirect	Direct/integrated	Pulse output	<b>WMM34.D002</b>
1.5 m <sup>3</sup> /h	1.5 m	Indirect	Direct/integrated	Radio 868 MHz	<b>WMM36.D001</b>
1.5 m <sup>3</sup> /h	2.5 m	Indirect	Direct/integrated	Radio 868 MHz	<b>WMM36.D002</b>

\* Prepared for communication with M-bus

\*\* Short designation: **Measuring cell**

### Type summary - measuring cell type heat meters $Q_p = 2.5 \text{ m}^3/\text{h}$

Nominal flow $q_p$	Cable length Temperature sensor	Flow sensor	Return sensor	Communication	Type reference **
1.5 m <sup>3</sup> /h	1.5 m	Indirect	Direct/integrated	For M-bus *	<b>WMM31.E001</b>
1.5 m <sup>3</sup> /h	2.5 m	Indirect	Direct/integrated	For M-bus *	<b>WMM31.E002</b>
1.5 m <sup>3</sup> /h	1.5 m	Indirect	Direct/integrated	Pulse output	<b>WMM34.E001</b>
1.5 m <sup>3</sup> /h	2.5 m	Indirect	Direct/integrated	Pulse output	<b>WMM34.E002</b>
1.5 m <sup>3</sup> /h	1.5 m	Indirect	Direct/integrated	Radio 868 MHz	<b>WMM36.E001</b>
1.5 m <sup>3</sup> /h	2.5 m	Indirect	Direct/integrated	Radio 868 MHz	<b>WMM36.E002</b>

\* Prepared for communication with M-bus

\*\* Short designation: **Measuring cell**

## Scope of supply - measuring cell type heat meters

Item	Temperature sensor, length and type of immersion		Packaging
	Measuring cell, 2" external thread, 1.5 m, indirect	Measuring cell, 2" external thread, 2.5 m, indirect	
Flow measuring section	•	•	Box
Display unit (ALU)	•	•	Box
Temperature sensors with fitting	•	•	Box
Protective cap	•	•	Box
WME.PRODICHT profiled gasket	•	•	Box
Wall mounting bracket	•	•	Box
Mounting Instructions	•	•	Box
Commissioning and Operating Instructions	•	•	Box
Seal wire	2×	2×	Bag 1
Self-lock seal	2×	2×	Bag 1
Adhesive label	1×	1×	Bag 1
S6 Fischer dowel	2×	2×	Bag 2
C 4 screws, 2×25	2×	2×	Bag 2

## Type summary - installation kits for return pipe

Scope of supply, description	Type reference
1× single-pipe connecting piece ¾" external thread, 18 mm solder, 1× locking ring, 1× profiled gasket, 2× ball valves without sensor connection; ½" internal thread with captive ¾" internal thread cap nut	<b>WMZ.E18/H</b>
1× single-pipe connecting piece ½" external thread, 15 mm solder, 1× locking ring, 1× profiled gasket, 2× ball valves without sensor connection, ½" internal thread on both sides	<b>WMZ.E15/H</b>

## Type summary - accessories

Accessory	Description, scope of supply	Type reference
EAT 15 mm solder	Single-pipe connecting piece ½" external thread, 15 mm solder, installation length 110 mm	<b>WME.L15/H</b>
EAT 18 mm solder	Single-pipe connecting piece ¾" external thread, 18 mm solder, installation length 110 mm	<b>WME.L18/H</b>
EAT 22 mm solder	Single-pipe connecting piece without external thread, 22 mm solder, installation length 130 mm	<b>WME.L22/H</b>
EAT 80 mm	Single-pipe connecting piece ¾" internal thread, installation length 80 mm	<b>WME.G20/H</b>
EAT 130 mm	Single-pipe connecting piece 1" external thread, installation length 130 mm ( <b>only for measuring cell Qp = 2.5 m<sup>3</sup></b> )	<b>WME.G22</b>
T-piece	½" internal thread, with M10×1 immersion sleeve	<b>WFZ.T16</b>
T-piece	¾" internal thread, with M10×1 immersion sleeve	<b>WFZ.T19</b>
T-piece	1" internal thread, with M10×1 immersion sleeve	<b>WFZ.T22</b>
M-bus connection set	1 plug with cable (1 m long); 1 factory seal	<b>WFZ.MBUSSET</b>
Bezel	Only for surface mounting, when the display unit is installed separately from the flow measuring section	<b>WFZ.B4</b>

## Ordering

---

When ordering, please give type references according to "Type summary". The electronic heat meter measuring cell is equipped with M-bus output as standard. If the heat meter is connected to a M-bus metering system, the M-bus connection set must be ordered. For the pulse output version, the M-bus connection kit is also required. If a set day other than December 31 is required, that date must be added to the type reference when ordering (normally, the last day of a month is the set day).  
Ordering example for a measuring cell type heat meter with April 30 as the set day:  
**WMM21.D001, set day: April**

## Technical design

---

### Measuring principle

The meter uses the multi-jet measuring principle. Rotation of the impeller is sensed electronically without a magnetic field.  
The flow and return temperatures are acquired with Pt 500 immersion sensors (platinum sensing elements).

### Acquisition of heat consumption

The heat meter is designed for installation in the return pipe.  
The flow measuring section measures the flow continuously and acquires the flow and return temperatures at least once in four minutes. It ascertains the temperature differential and uses this to calculate the quantity of heat consumed based on the average flow and the thermal coefficient.

### Storage of consumption values

The heat consumption values are continuously accumulated. On the next set day, the current reading will be stored at 23.59 h.  
The set day can be programmed in the factory. Standard setting is December 31 (refer to "Ordering").  
At the time the annual consumption values are stored, the heat meter calculates a check sum. Tenants who do their own reading must notify the billing office of this check sum along with the set day value reading so that the office can check to ensure that the display has been read correctly.  
The set day value stored is kept for one year.

### Display

The heat meter has 3 display levels; these include the following values and quantities:  
**(One display level is not available with the radio 868 MHz versions)**

- Cumulated heat consumption on the last set day
- Segment test
- Current heat throughput
- Current flow
- Current flow temperature
- Current return temperature
- Current temperature differential
- Number of operating hours since the heat meter was commissioned
- Set day and set month
- Heat consumption stored in the previous year
- Heat consumption stored in the last 15 months (**not available with the radio 868 MHz versions**)
- Check sum
- Cumulated heat consumption since the heat meter was commissioned
- Error display (see next section)

The units displayed are °C or K, kWh (or GJ on request), m<sup>3</sup>/h, kW and hours.  
The cumulated heat consumption is the default display.

## Error messages

The heat meter is a self-monitoring device and can display the errors it has identified. It can distinguish between 2 categories of error:

- Temporary errors: These do not impair the operation of the heat meter
- Severe functional errors: No further measurement are made. The error display (number) and the date on which the error first occurred appear alternately on the display. The values cumulated until the error first occurred remain stored

## Mechanical design

---

The heat meter consists of flow measuring section, display unit (ALU) and 2 temperature sensors. The flow measuring section is installed in the single-pipe connecting piece located in the pipe. It is made of brass and contains the multi-jet measuring chamber with the impeller. The water inlet has a strainer to trap larger dirt particles. The heat meter is of compact design. The display unit can be installed separately however.

## Display unit

The display unit contains the electronics and the 8-digit display (LCD). A lithium battery supplies the DC 3 V operating voltage. A button to advance the display is located underneath the display.

The display unit can be rotated by 270° on the flow measuring section and swiveled through 90°.

## Temperature sensors

The flow temperature sensor is fitted indirectly immersed using a hasped screw, the return temperature sensor is integrated directly immersed in the measuring cell.

The flow temperature sensor comprises the protective sleeve, at the end of which the Pt 500 sensing element is located, and the shielded silicon cable, which connects it firmly to the display unit.

The temperature sensors used are ready mounted, approved, paired and certified.

## Mounting notes

---

### Electrostatic Sensitive Devices



All modules integrated in the meters are electrostatically endangered components. The freely accessible contacts (cable end, plug connector) are only partially protected against interference.

Skilled personnel should avoid wearing polyester clothing and shoes with plastic soles as this type of clothing promotes electrostatic charging.

Electrostatic charging of skilled personnel must be deflected when handling open components e.g. by touching an earthed piping system.

## Mounting

- Local regulations for the use of heat meters (installation, sealing, operation, etc.) must be complied with
- The heat meter must be installed in the return between 2 shutoff valves. It must be easily accessible for reading and servicing
- If the heat meter is first used at the time of commissioning, the single-duct connecting piece with gasket and sealing cap can be installed beforehand
- Prior to installing the meter, the piping must be thoroughly flushed; to do this, the single-pipe connecting piece must be mounted
- When installing the single-pipe connecting piece, the flow sign - an arrow on the single-pipe connecting piece - must be observed
- If using T-pieces from other manufacturers, check to ensure that they comply with standard EN 1434!
- The display unit can be installed separately from the flow measuring section  
If the aperture in the wall is too large for the display unit, it can be installed using the mounting plate. If necessary, a chrome-plated covering plate can be fitted
- The unit should be placed so that the display is easy to read
- After installation, the system must be pressure-tested

- Seals must be used to protect the display unit, the 2 temperature sensors and the fittings against unauthorized access.  
If necessary, the M-bus service interface must also be sealed
- The pipe must be insulated at the location where the temperature sensors are fitted

### Operating notes

- Local regulations must be observed when recalibrating the meter

### Measurement

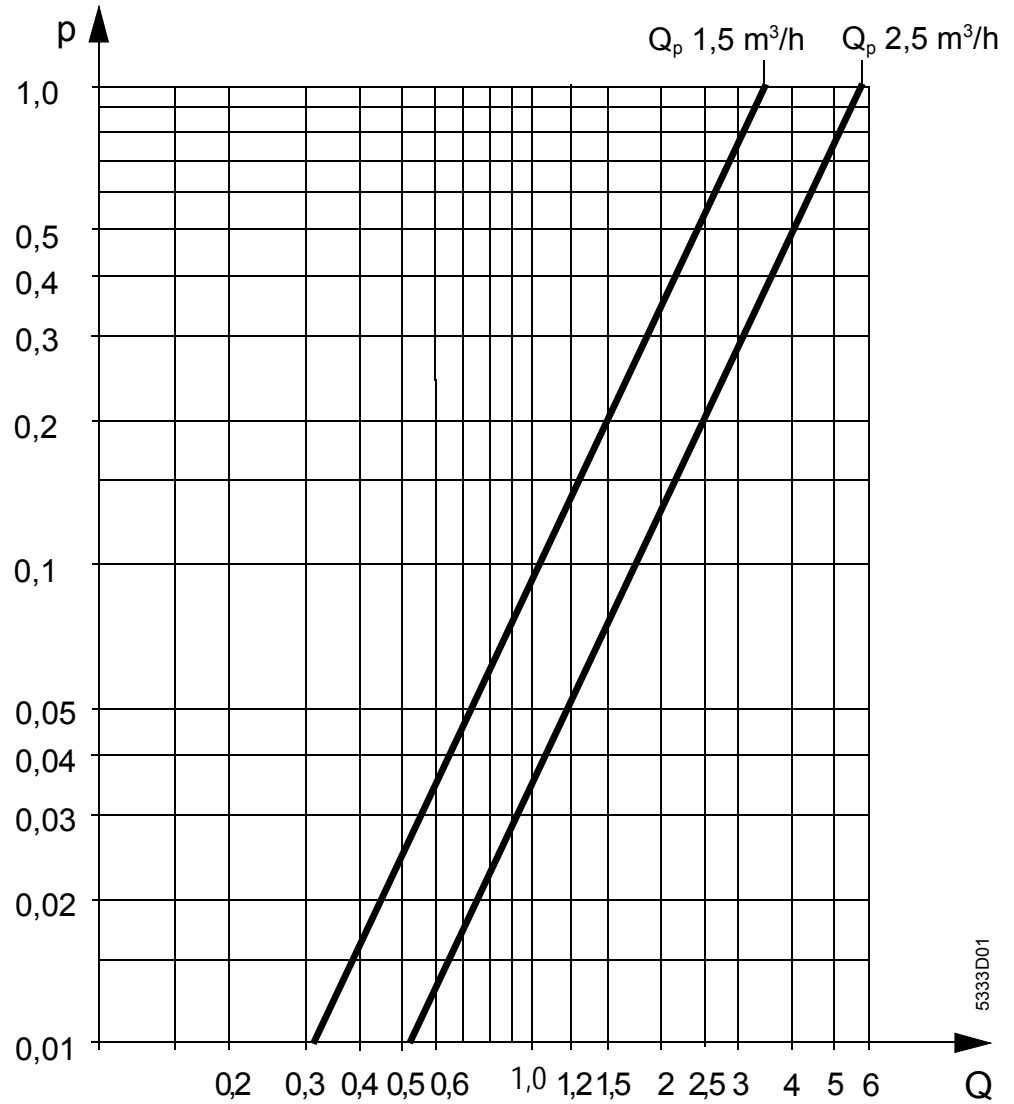

Pressure loss characteristic curve

$\Delta p$  Druckverlust in bar  
 $Q$  Durchfluss in  $m^3/h$

## Technical data

Metrological class	to DIN ISO 4064/1	
Meter body mounted horizontally	B	
Meter body mounted vertically	B	
Energy unit		
Standard	kWh	
On request	GJ	
Max. measurable heat output	300 kW	
Flow values	$Q_n 1,5 \text{ m}^3/\text{h}$	$Q_n 2,5 \text{ m}^3/\text{h}$
Min. flow $q_i (Q_{\min}) \text{ H / V}$	30 l/h	50 l/h
Nominal flow $q_p (Q_{\text{nenn}})$	1500 l/h	2500 l/h
Max. flow $q_s (Q_{\max})$	3000 l/h	5000 l/h
Starting value horizontally	5 l/h	8 l/h
Max. permissible operating pressure	10 bar	
Operating limits flow measuring section	1... 90 °C	
Temperature measurement		
Measuring range	20...110 °C	
Temperature differential	3...90 °C	
Start temperatures	$\geq 1 \text{ °C}$ and $\Delta T \geq 0,6 \text{ K}$	
Output signal		
Under measuring conditions	optional M-bus (EN 1434)	
In test operation	optional M-bus (EN 1434) optional voltage pulses (DC 3 V)	
Perm. ambient temperature		
Transport and storage	5...55 °C	
Operation	max. 55 °C	
Battery life	>10 years	
Connection sizes and weights		
Pipe connection	single-pipe connecting piece (EAT)	
Installation length	110 mm	
Weight	0.51 kg	
Temperature sensor		
Sensing element	Pt 500 $\Omega$ to EN 60751	
Connecting cable	1.5 or 2.5 m	
Pulse output data		
Pulse output	open collector, protective resistor 2440 $\Omega \pm 10 \%$	
Reversal of polarity	not possible	
Pulse length	$\geq 100 \text{ ms}$	
Pulse pause	$\geq 100 \text{ ms}$	
Max. voltage	<30 V	
Max. current	$\leq 0.1 \text{ mA}$	
Capacitance to water pipe	10 nF (50 V)	
Pulse valency	1 kWh per pulse (heat energy)	
<b>Note:</b>	The service tools ACC210, AZS210 and ABS210 can <b>not</b> be used with the pulse output meter!	

## Dimensions

Display unit can be swiveled through 90°, locked into position and continuously rotated through 360°

Display unit can be removed in this position

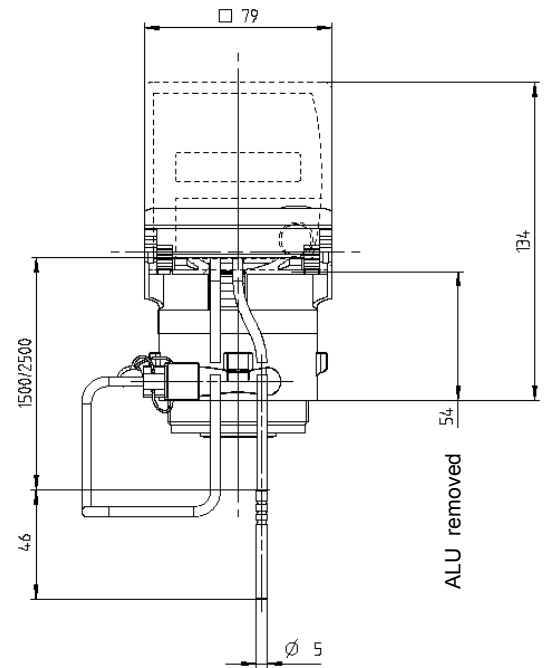
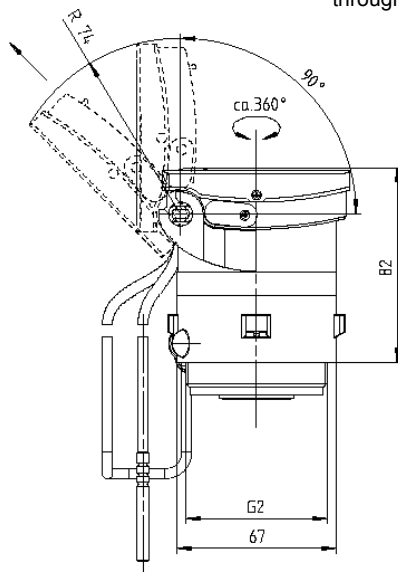

This Data Sheet only contains general descriptions and technical features which, in the case of specific applications, may not necessarily apply, or which may change due to further development of the product. Technical details and features are binding only if explicitly agreed upon at the time of contract closure.

©2010 QUNDIS GmbH  
Subject to alterations